

## RX-8 Oil Cooler Hose Set

Part No. 11911

### Installation Instructions

RX8 Oil Line Kit 2004~2008 (For applications with 2 oil coolers)

Changing the RX-8 oil hoses is a complex job, easier to accomplish if undertaken while the engine is out of the chassis. This project can be undertaken with the engine installed, however, it is a job must NOT be rushed. This installation effort requires the removal of the eight (8) stock oil lines, we suggest you allocate adequate time to accomplish this job. We suggest washing out the engine compartment before starting this job, including the underside of the car.

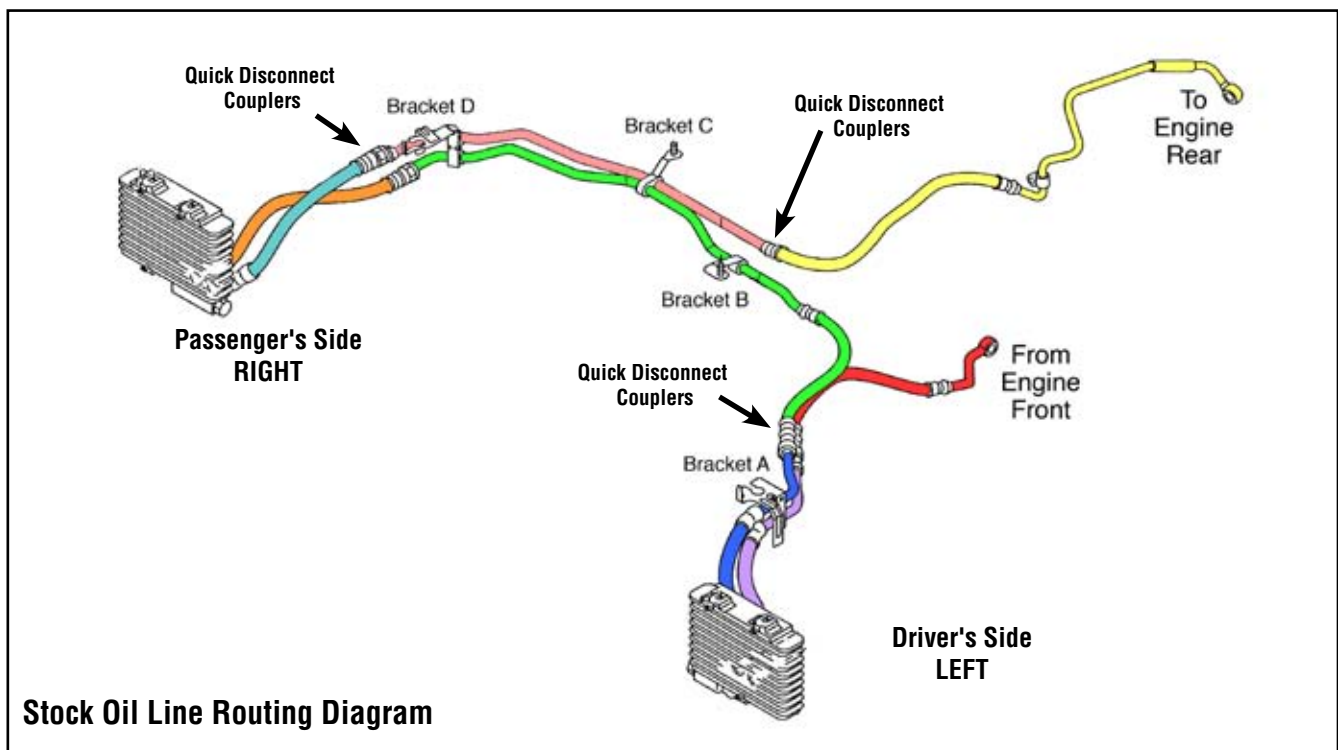

### Installation Instructions

1. Begin the oil line set installation by removing:
  - Engine cover
  - Strut brace
  - Battery and battery box
  - Air filter box and tray (if a Racing Beat intake is installed, remove the filter from the rear of the box, then remove the fasteners from the interior)
  - Upper intake manifold
  - Oil vent/filler assembly
  - Ignition coils
  - A/C compressor from engine (do not remove hoses or electrical connector)
2. Raise the car and place on jack stands.

**3. Remove:**

- Lower front plastic panels from both wheel wells
- Front center plastic under tray

4. Disconnect the (4) oil lines from both oil coolers and allow the hoses and coolers to drain.

**5. Remove:**

- (5) spring clips that retain the oil lines "quick-disconnect" couplers.
- Left and right oil cooler lines (4 lines)
- Center rigid oil lines - Remove out through the right front wheel well. (2 lines)
- Front engine oil line - From engine front to cooler. (1 line)
- Rear engine oil line - To engine rear from cooler. (1 line)
- Electrical connector from the crank trigger pickup (to allow engine cranking during final testing)

**6. Install:**

- Reattach A/C compressor to engine
- Reattach oil vent/filler assembly
- Re-install Ignition coils
- Install the (6) supplied Racing Beat oil adapter fittings onto the engine and oil coolers.
  - Note: Re-use the (6) copper washers removed earlier, coat with silicone seal.
  - Note: Place the supplied protective caps over the installed adaptor fittings to ensure safety and cleanliness.

**Retaining Bracket Preparation :**

Lay out the hoses removed earlier as they were installed in the car. Mark the (4) stock support brackets as follows (from the driver's point of view: Bracket A - Left fender well; Bracket B - Left of center (1 tube); Bracket C - Right of center (2 tubes); Bracket D - Right fender well. Remove all the brackets from their tubes. (Refer to the routing diagram on page 1 if needed.)

**7. Bracket A & D Preparation:**

Drill or punch  $3/16$ " holes in parts A and D 1.5" from the large hole.

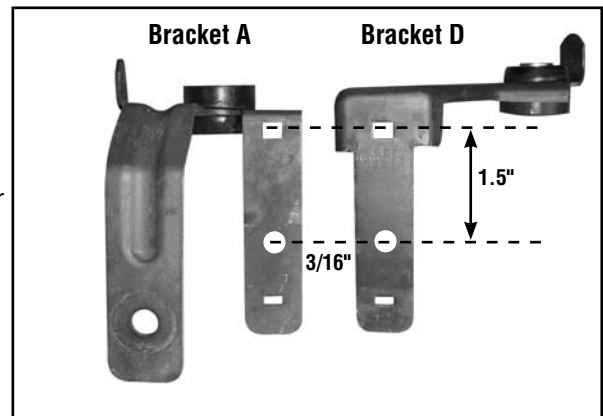
**8. Bracket C Preparation:**

Uncurl the bracket and hammer it flat as shown in the picture progression. Punch or drill a  $3/16$ " hole 2.5" from the bend, then cut off the excess 2.9" from the bend.

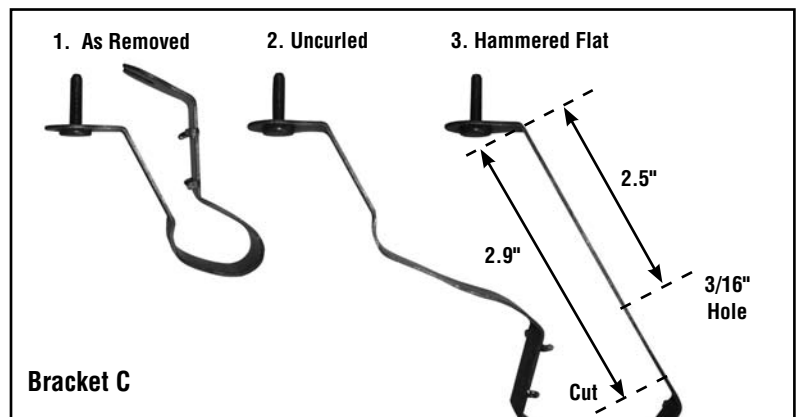

9. Bracket B: Uncurl the part and hammer it flat as shown in the photo progression. Punch or drill a 3/16" hole 2" from the bend, then cut off the excess 2.4" from the bend.

**Installation:**

**Note:** It is important when installing the hoses on the coolers that the oil enters the coolers from the "outboard" side and exit via the "inboard" side.

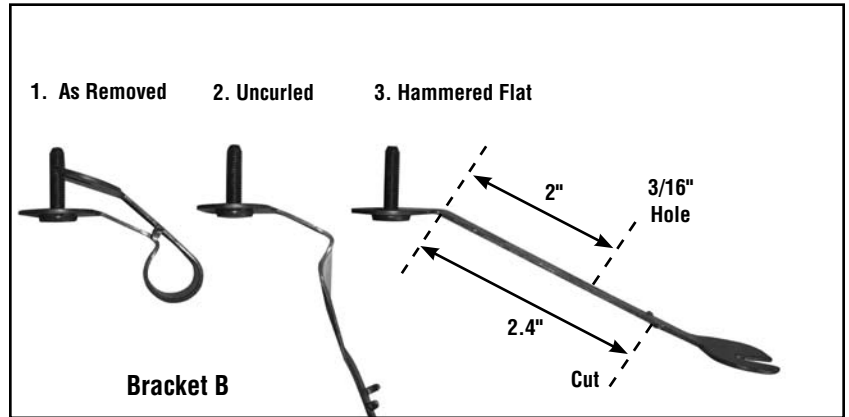

10. Remove the plastic plugs and verify that the hoses are clean. Spray WD-40 or equivalent on the threads. Re-install the plastic plugs to keep dirt out.

11. **Engine front to driver's side oil cooler hose** - Install the "engine outlet" hose (shortest hose) first. The end of the hose closer to the red "shrink wrap" attaches to the engine. The hose ends may be rotated relative to the blue 15/16" nut to facilitate installation. See the photos below for routing and orientation.



Connect oil line to adaptor installed on the engine front cover as shown.

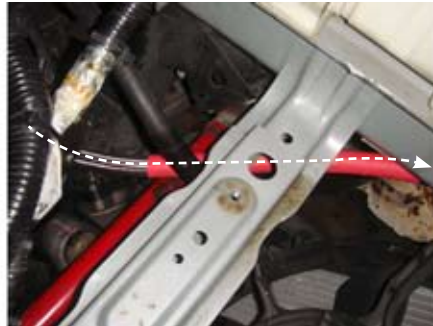

Route oil line forward under the air box support cross member.



Connect oil line to the adaptor installed on the OUTER connection on the cooler.

12. **Engine rear (inlet) to passenger side oil cooler** - Install the "engine inlet" hose (identified as the hose with the 45° hose end fitting). Connect the 45° end fitting to the adaptor on the engine rear inlet filter adaptor. Attach to the engine first, then route the hose under the wiring harness and across the engine bay. Connect to the INBOARD fitting on the passenger side cooler.



Attach the 45° connector to the adaptor on the rear of the engine. Route the oil line under the wiring harness...



... then route the oil line through the engine compartment as shown and connect to the INBOARD fitting on the passenger side cooler.

13. **Oil cooler to oil cooler hose** - Install the "cooler-to-cooler" hose last. Attach end closer to red shrink wrap to driver's side cooler INBOARD adaptor fitting first, then route as shown and attach the oil line to passenger's side OUTBOARD adaptor fitting.



Attach the connector to the INBOARD adaptor on driver's side cooler. Route the oil line across the engine compartment and under the cross member...



... then connect to the OUTBOARD adaptor fitting on the passenger side cooler.

#### Retaining Bracket Installation

The original support brackets that were removed and modified will be reused in the following steps:

14. Retaining Bracket A - Using the supplied 3/16" bolt and nut, assemble Bracket A and (2) Adel loop clamps on the driver's side cooler lines but leave the bolt loose to allow adjustment of the hose position. Use the new hole position on the bracket to secure the clamps to the bracket. Mount bracket A to the chassis in its original position.

15. Retaining Bracket D - Using the supplied 3/16" bolt and nut, assemble Bracket D and (2) Adel loop clamps on the passenger's side cooler lines but leave the bolt loose to allow adjustment of the hose position. Use the new hole position on the bracket to secure the clamps to the bracket. Mount bracket D to the chassis in its original position.

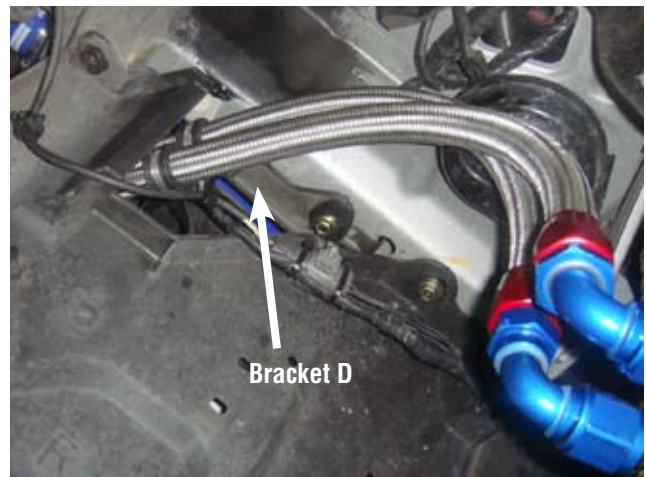
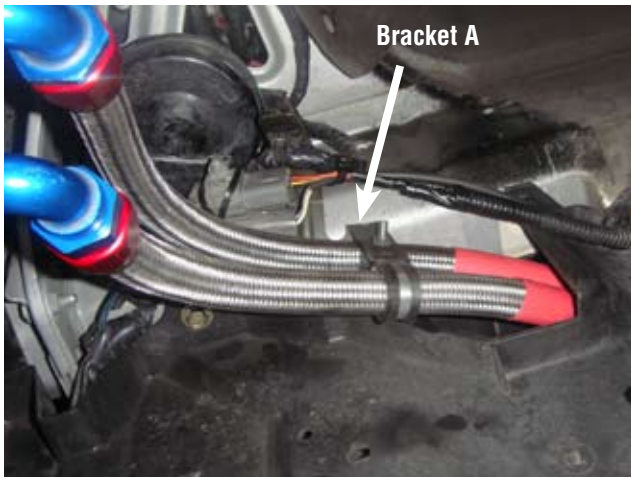

16. Retaining Brackets B & C - Note the orientation of brackets B and C in the photos. Using the Adel loop clamps and supplied 3/16" bolt and nut, assemble your components on the hoses centered on the marked lines on the hoses in the same orientation as shown. Use the new hole position on the bracket to secure the clamps to the bracket. Do not tighten the 3/16" bolts. Install brackets B and C to the cross member in their original positions.

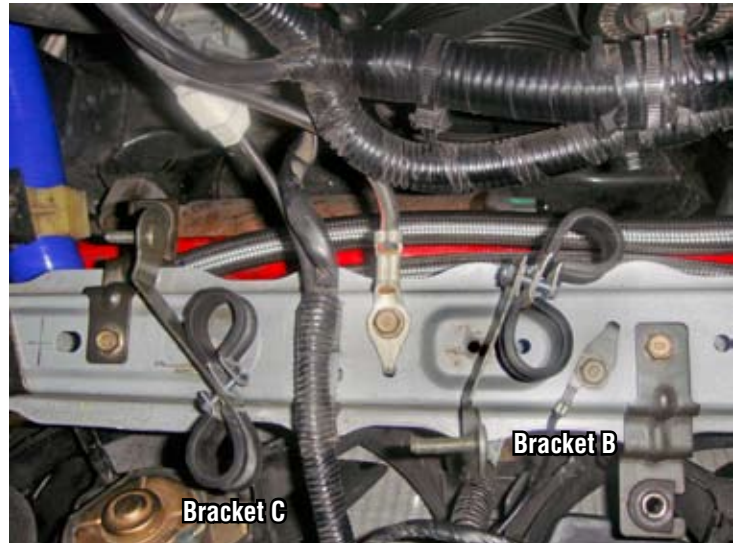

17. Check the orientation of the hose into the filter adapter for clearance (it should be angled up slightly). Install (3) tie wraps between this hose and the A/C hoses positioned adjacent. (See arrows.)



18. Install (1) tie wrap between the engine oil outlet hose and the A/C hose.



19. With the hoses now connected, inspect the installation carefully for any signs of hose strain or chafing. Correct any problem by shifting the hoses in their clamps, bending the brackets, adjusting the hose end rotational position or adjusting the hose twist.
  20. Tighten the (4) 3/16" clamp bolts to firmly secure the Adel loop clamps. Recheck hose routing and clearance.
  21. Re-assemble all components except the crank trigger connector and the left and right wheel well plastic panels.
  22. Crank the engine for 15 seconds, wait 10 minutes, then repeat. Check oil level (probably down [1] quart). Re-connect the crank angle sensor. Start engine and check the installation for any signs of leakage. Re-install the wheel well plastic panels. Lower the car.
- The installation is complete.