

## 1986-1992 RX-7 Sway Bar Heavy-Duty Endlink Kit Part Number 14200

### INSTALLATION ON FRONT SWAY-BAR:

1. Jack up the car and place on safety stands. DO NOT work under a car supported only by a jack. Remove the wheels, then remove the stock endlinks.

2. Assemble the Racing Beat links, as shown in figure 1, and adjust to match the length and alignment of the stock links. Do not tighten the jam nuts at this time.

**Note:** You must have (8) threads of engagement between the link stud and the link head to ensure adequate strength of the link assembly.

3. Install the Racing Beat links as shown in the diagrams below. Do not use the stock lock washers and nuts. Installation is easier if the bottom bolts are inserted first. Tighten bolts to 27 ft/lbs.

4. Firmly tighten the jam nuts on the Racing Beat links.

5. Re-install the wheels. If you are installing a link kit on the rear of the car, proceed with the instructions on the following page. If not, lower the car.

For additional Tuning Tips, see the bottom of the following page.

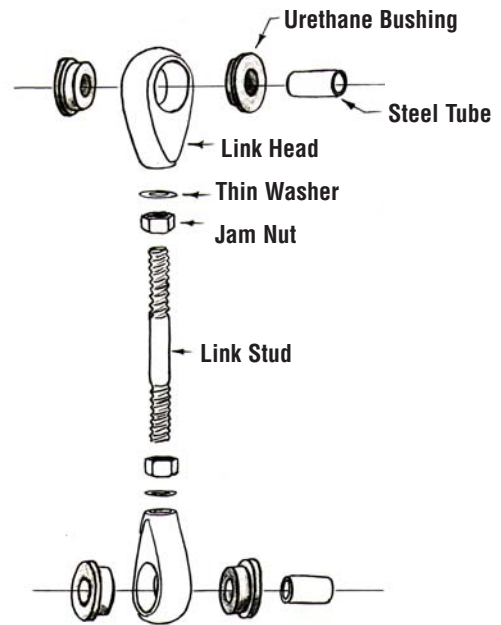
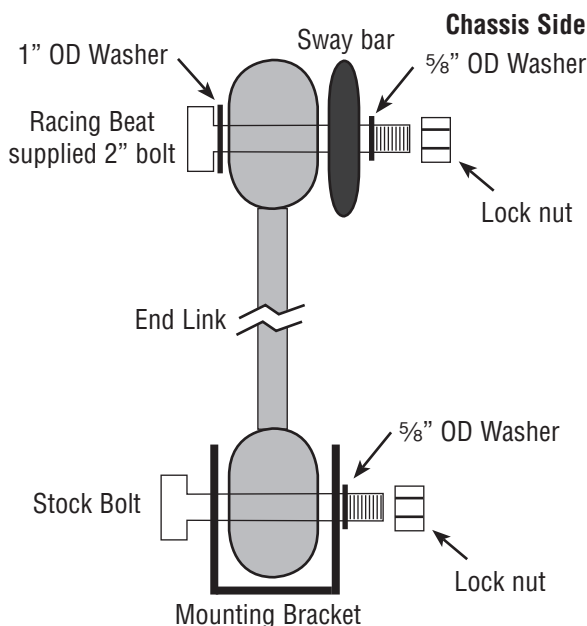
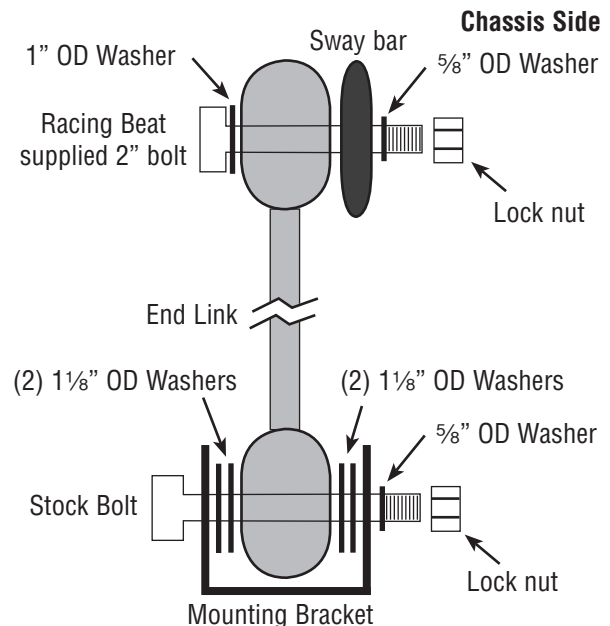

Figure 1 - Link Assembly

### 1986-88 RX-7 Front



### 1989-92 RX-7 Front



## INSTALLATION ON REAR SWAY-BAR:

1. Jack up the car and place on safety stands. DO NOT work under a car supported only by a jack. Remove the wheels, then remove the stock endlinks.
2. Assemble the Racing Beat links, as shown in figure 1, and adjust to match the length and alignment of the stock links. Do not tighten the jam nuts at this time. **Note:** You must have (8) threads of engagement between the link stud and the link head to ensure adequate strength of the link assembly.
3. Install the Racing Beat links as shown in the diagrams below. Do not use the stock lock washers and nuts. Installation is easier if the bottom bolts are inserted first. Tighten both bolts on each side to 27 ft/lbs.
4. Install the Racing Beat links using the stock bolts (as indicated) on the bottom and the extra length bolts and nylock nuts (supplied in the kit) on the top. Install the bottom bolts first, placing one of the 1" washers between the lockwasher and the link. Install the extra length upper bolts through the sway bar and link with the bolt head ON THE INSIDE, against the sway bar. This is necessary to avoid contact between the bolt and the chassis when the suspension is compressed. Install one of the 1" washers and a nylock nut on each upper bolt. Tighten both bolts on each side to 27 ft/lbs.
5. Firmly tighten the jam nuts on the Racing Beat links. Re-install the wheels and lower the car.

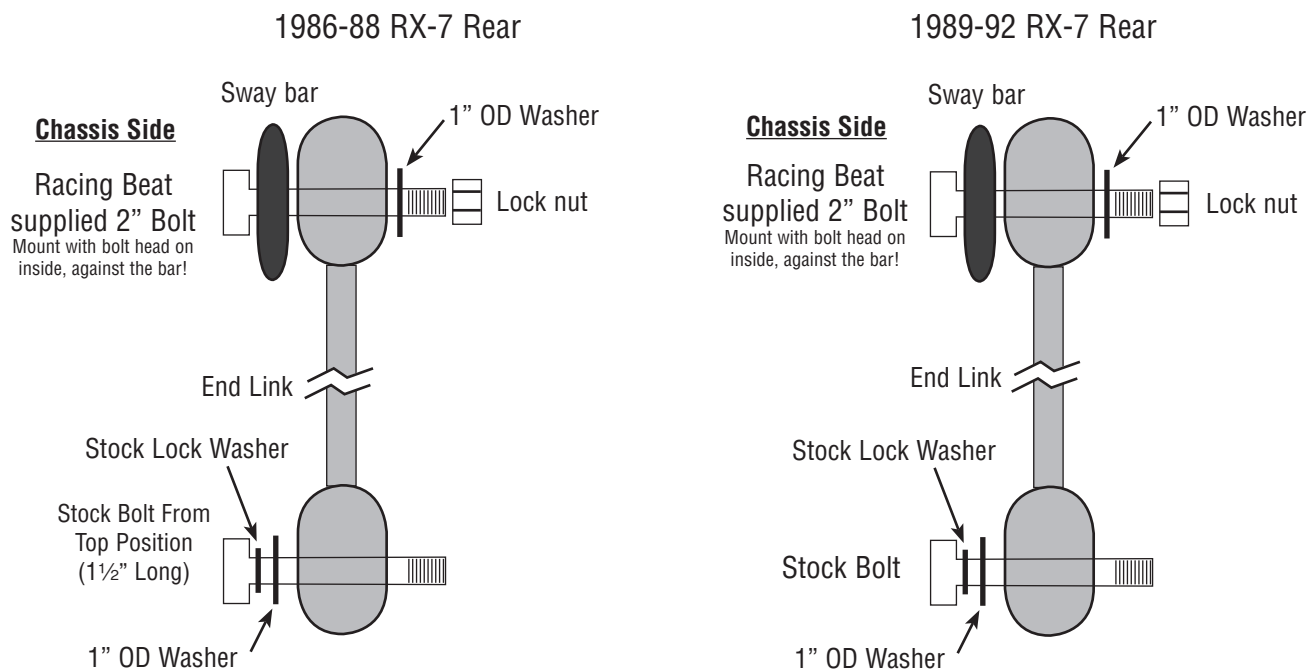

### Tuning Tips

if you are particularly sensitive to the handling of your car, you may wish to make the extra effort of setting the neutral position of the anti-roll bar links. This is accomplished by parking the car on a perfectly level spot and adjusting the length of one of the links on each bar so that there is no load on the sway bar. We recommend that you make this adjustment by shortening the links rather than lengthening them. In extreme cases it may be necessary to shorten the link studs to prevent the stud tips from being screwed into the urethane bushings.

It is also possible to "jack" weight from one corner of the car to another by intentionally mismatching the length of the links. We do not recommend weight jacking for street use.

If you have adjusted the Racing Beat links to a non-stock length, you must check carefully to ensure that the sway bar and links will not strike any part of the chassis, brake lines, suspension, differential, radiator, etc.. at any point in the travel of the suspension.