

Gasket & O-Ring Kit Includes The Following Items:

10-271S

- 1-RING SET."O".....(1)
- 2-GASKET,OIL FLLER PIPE... (1)
- 3-GASKET,OIL PAN.....(1)
- 4-GASKET,FRON COVER.....(1)
- 5-GASKET.....(1)
- 6-GASKET,IN.MANIFOLD.....(1)
- 7-GASKET NO.2,IN. MANIFOLD (1)
- 8-GASKET.....(2)
- 9-GASKET,EX.MANIFOLD.....(1)
- 10-GASKET,FUEL DIS.....(2)
- 11-GASKET,EXH.PIPE.....(1)
- 12-GASKET,OIL PIPE.....(1)
- 13-GASKET,OIL PIPE.....(2)
- 14-GASKET,TURBO CHARGER....(1)
- 15-GASKET.....(1)
- 16-GASKET,A.C.VALVE.....(1)
- 17-GASKET,OIL STRAINER.....(1)
- 18-GASKET,OIL STRAINER.....(1)
- 19-GASKET,METERING OIL.....(1)
- 20-GASKET,WATER PUMP.....(1)
- 21-GASKET.....(1)
- 22-GASKET,THERMOSTAT COVER.(1)
- 23-GASKET,B.A.C.VALVE.....(1)
- 24-GASKET.....(4)
- 25-GASKET.....(8)
- 26-GASKET.....(2)
- 27-GASKET.....(1)
- 28-GASKET.....(4)
- 29-GASKET.....(3)

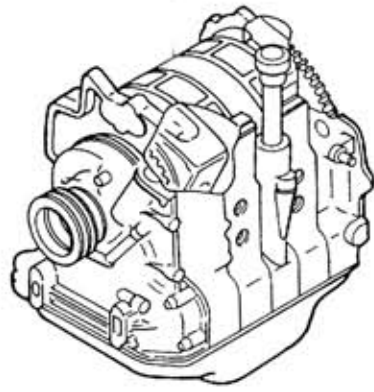

- 6-GASKET,IN.MANIFOLD.....(1)
- 7-GASKET NO.2,IN. MANIFOLD (1)
- 9-GASKET,EX.MANIFOLD.....(1)
- 25-GASKET.....(8)
- 30-RING"O".....(1)

13-111S

